



The Clear Choice
Water Filtration Systems

www.aquafilter.com

H05A series

**5" three-part filter housings
for cold water**



Made in EU

General Description:

AQUAFILTER FHPR5-x, FHPRN5-x, FHPR5-x-WB, FHPR5-x-WB - 5" three-part filter housings offer the versatility to meet all customer filtration needs.

FHPR5-x, FHPRN5-x, FHPR5-x-WB, FHPR5-x-WB are dedicated for cold water on light commercial and residential applications. **FHPR5-x, FHPRN5-x, FHPR5-x-WB, FHPR5-x-WB** housings are compatible with a broad range of 2 1/2" x 5" type cartridges widely available on the market.

Filter housing consists of: a sump, ring and head with brass 1/2", 3/4" and 1" inlet/outlet inserts. Heads are equipped with a pressure relief valve (providing ability to release air bubbles collected during cartridge replacement procedure).

The tri-part design ensures maximum leak proof performance and ease of filter cartridge replacement.

The **FHPR5-x, FHPRN5-x, FHPR5-x-WB, FHPR5-x-WB** series housings can be mounted individually or connected in a series.

The **FHPR5-x, FHPR5-x-WB** series housings were tested and certified by NSF for structural integrity and material requirements.

FHPR5-x-WB is equipped with mounting bracket and wrench.

Features:

- Made in EU with High Performance Components
- High quality
- NSF certified for structural integrity and material requirements*
- WRAS certificate*
- FDA CFR Title 21 Compliance
- Competitive Pricing
- Hand Built & Factory Tested
- Domestic and commercial use
- Three-part design (ideal connection stability)
- Equipped with filter bracket and wrench**
- Ideal for POE use
- Maintenance Free -Saves \$, Time and Labor
- Easy to connect to cold water inlet
- Easy to install, No Electricity, No Drain Required
- Full flow 1/2", 3/4" or 1" ports

* only in **FHPR5-x, FHPR5-x-WB,**

** only in **FHPR5-x-WB, FHPRN5-x-WB**

Application:

- Domestic installations
- Pre-filtration systems
- Food industry
- Industry laboratories



Part Nr.	Size
FHPR5-12	1/2"
FHPR5-34	3/4"
FHPR5-1	1"

Part Nr.	Size
FHPR5-12-WB	1/2"
FHPR5-34-WB	3/4"
FHPR5-1-WB	1"

Item sold as set, include:

- filter housing,
- mounting bracket,
- wrench
- bacteriostatic cartridge centralizing ring
- instruction
- color box.



This Filter Housing is Tested and Certified by NSF International against NSF/ANSI Standard 42 for structural integrity and materials requirements.

COMPONENT





The Clear Choice
Water Filtration Systems

www.aquafilter.com

H05A series

**5" three-part filter housings
for cold water**

Additional accessories

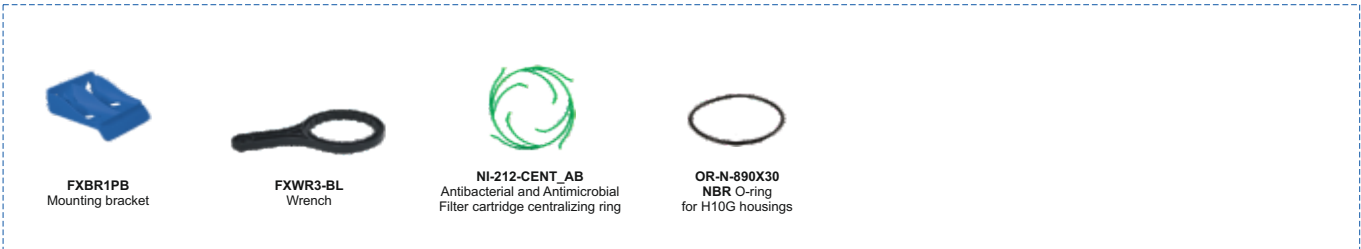

Specifications:

Housing (sump): poly(ethylene terephthalate) (PET)
Cap: polypropylene
Ring: polypropylene
Inserts: brass
Pressure relief valve: brass
O-ring: NBR
Thread: 1/2", 3/4", 1" BSP
Operating Pressure: 6 bar (90 psi)
Minimum working temperature: 2°C (35°F)
Maximum working temperature: 45°C (113.00°F)*
Dimensions without bracket (H x OD): 190 mm x 105 mm
Dimensions with bracket (H x W x L): 235 mm x 105 mm x 125 mm
Cartridge dimensions: 4 7/8" x 2 1/2" (125 mm x 65 mm)

* Tested and certified by WRAS for 23°C only.

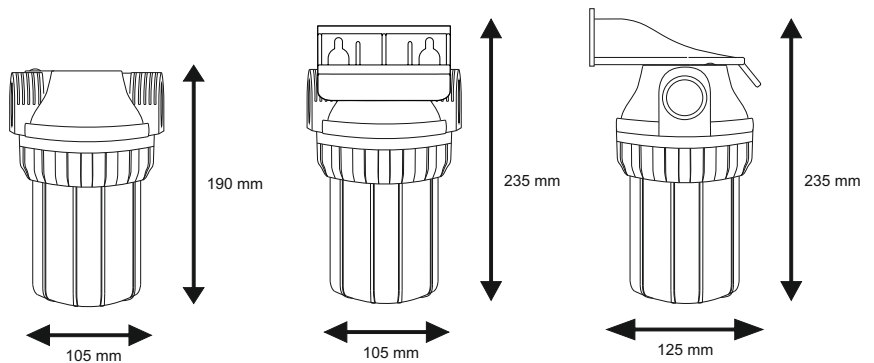
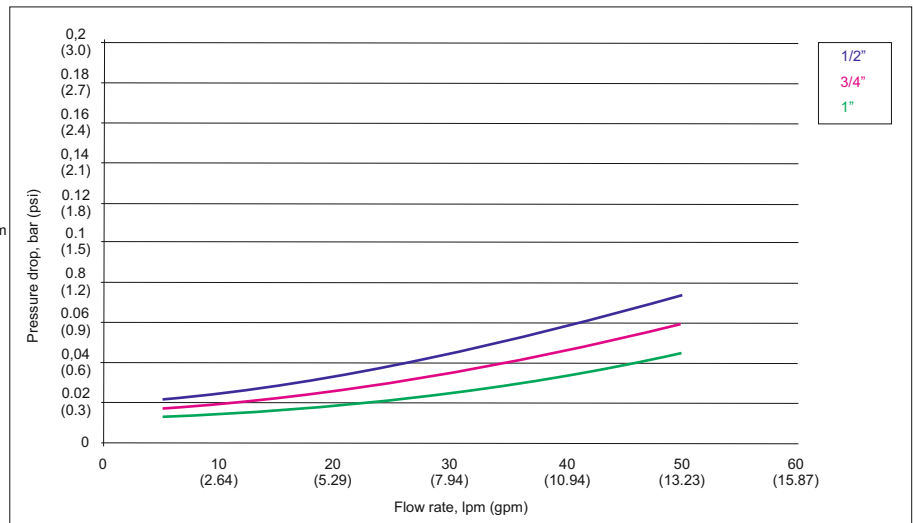

NOTE

- Do not use with water that is microbiologically unsafe or of unknown quality without adequate disinfection before or after the system.
- Water filtration systems can help reduce the presence of contaminants. In addition, some water filtration systems can help reduce the presence of microorganisms or other contaminants with potential health effects.
- We strongly recommend regularly scheduled maintenance and replacement of the filter cartridge in order for the product to perform properly.
- Replace the filter cartridge at least every 6 or 12 months (depending on water quality and water consumption)

LIMITED WARRANTY: Manufacturer warrants that this product is free from defects in materials and workmanship. This warranty, together with any and all warranties implied by law, shall be limited to a period of five (5) years from the date of original purchase.
 This limited warranty does not apply to failures that result from abuse, misuse, alteration or failure to properly comply with installation, or cartridge change instructions.
 We strongly recommend adding to all point of use and point of entry a Pressure Limiting Valve to guard against unwanted extreme water pressure events pressure increases, surges, and water hammer which could occur in the water pipes.
 Not having one installed could mean that if you ever did have to claim damage caused by a burst water filter system, the claim will be denied.

All Aquafilter images, trademarks, logos, and other intellectual property are the sole and exclusive property of Aquafilter, Inc. and may not be used without our express written permission.



**Aquafilter
Manufacturing
Facility**

Aquafilter Inc.
Hunt Valley 21030, USA
us@aquafilter.com

Aquafilter Germany
15234 Frankfurt, Germany
de@aquafilter.com

Aquafilter Europe
91-222 Lodz, Poland
pl@aquafilter.com

